

# Split Core Hall effect Current Sensor

## SCY6, SCY6R

### Product description

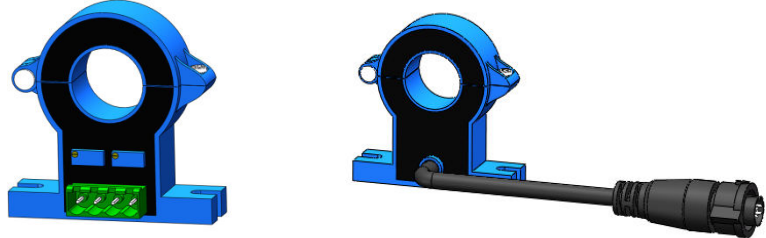

#### Features

- Based on Hall effect measurement principle, open loop circuit mode.
- The isolation voltage between primary and secondary is greater than 3000VAC.
- Can be opened and closed up and down, no need to disassemble the busbar, easy to install.
- Comply with UL94-V0 flame retardant rating.
- Provide lead output and use automotive special connectors (SCY6R Series)

#### Performance

- It can measure DC, AC, pulse, and various irregular waveform currents of cable conductors under isolation conditions.
- Wide measurement range, fast response speed, low zero drift, low temperature drift, high accuracy and good linearity.
- Dynamic performance (di/dt and response time) is optimal when the busbar is fully filled with primary perforations.
- Strong ability to resist external electromagnetic interference (BCI, EFT, CS, CE, ESD, dv/dt, etc.).

#### Application

- It can be widely used in communication power supply, UPS, photovoltaic inverter, electric vehicle drive and other products.

#### Implementation standards

- GB/T 7665-2005
- JB/T 7490-2007
- JB/T 25480-2010
- JB/T 9473-2020
- SJ 20792-2000

#### Certification



Shenzhen SoCan Technologies Co.,Ltd

SoCan is committed to continuously improving product quality, and the company reserves the right to update its products.

[www.szsocan.com](http://www.szsocan.com)

## Technical Parameters

Model	SCY6-/SCY6R-				
	50A	100A	200A	300A	500A
Parameters (25°C)	50A	100A	200A	300A	500A
Primary Current (A) $I_{PN}$	50A	100A	200A	300A	500A
Primary Current Max. Peak Value (A) $I_{PM}$	±100A	±200A	±400A	±600A	±1000A
Output voltage (V) $V_{out}$ @± $I_{PN}$ , $R_L=10K\Omega$	±4V (±1%)				

## Electrical Data

Item	Min.	Typical	Max.	Unit
Input power supply voltage range $V_c$ (±5%) (Remark 1, Remark 2)	±11	±12	±18	$V_{DC}$
Current consumption $I_c$	-	±15	±20	mA
Withstand resistance $R_{INS}$ @500V DC	1000	-	-	$M\Omega$
Output voltage $V_{out}$ @ $I_{PN}$ , $R_L=10K\Omega$ , $T_A=25^\circ C$	$V_{OUT} = 4.04 * \frac{R_L}{102 + R_L} * \frac{I_P}{I_{PN}} + V_{OE}$			V
Output internal resistance $R_{OUT}$	-	102	-	$\Omega$
Load Resistance $R_L$ (Remark 3)	-	10	-	$K\Omega$
Accuracy X @ $I_{PN}$ , $T_A=25^\circ C$	-	±1	-	%
Linearity $\epsilon_L$ @ $R_L=10K\Omega$ , $T_A=25^\circ C$	-	±1	-	% $I_{PN}$
Offset voltage $V_{OE}$ @ $T_A=25^\circ C$	-	±20	±30	mV
Hysteresis voltage $V_{OM}$ @ $I_{PN} \rightarrow 0$	-	±15	±25	mV
Temperature Coefficient of Offset Voltage $TCV_{OE}$	-	±0.5	±1	mV/°C
Output voltage temperature coefficient $TCV_{out}$	-	±0.08	±0.15	%/°C
Response time $t_D$ @ $0 \rightarrow I_{PN}$ (Remark 4)	-	3	5	us
Ambient operating temperature $T_A$	-40	25	125	°C
Ambient storage temperature $T_s$	-40	25	125	°C
Withstand voltage $V_D@50Hz, 60s, 0.1mA$		3000		$V_{AC}$
Weight m		65		g

Remarks:

VC less than the minimum value will result in inaccurate measurements, and VC greater than the

Shenzhen SoCan Technologies Co.,Ltd

SoCan is committed to continuously improving product quality, and the company reserves the right to update its products.

[www.szsocan.com](http://www.szsocan.com)

maximum value will cause the measurement device to fail permanently.

## Dimensions (in mm)

### SCY6T

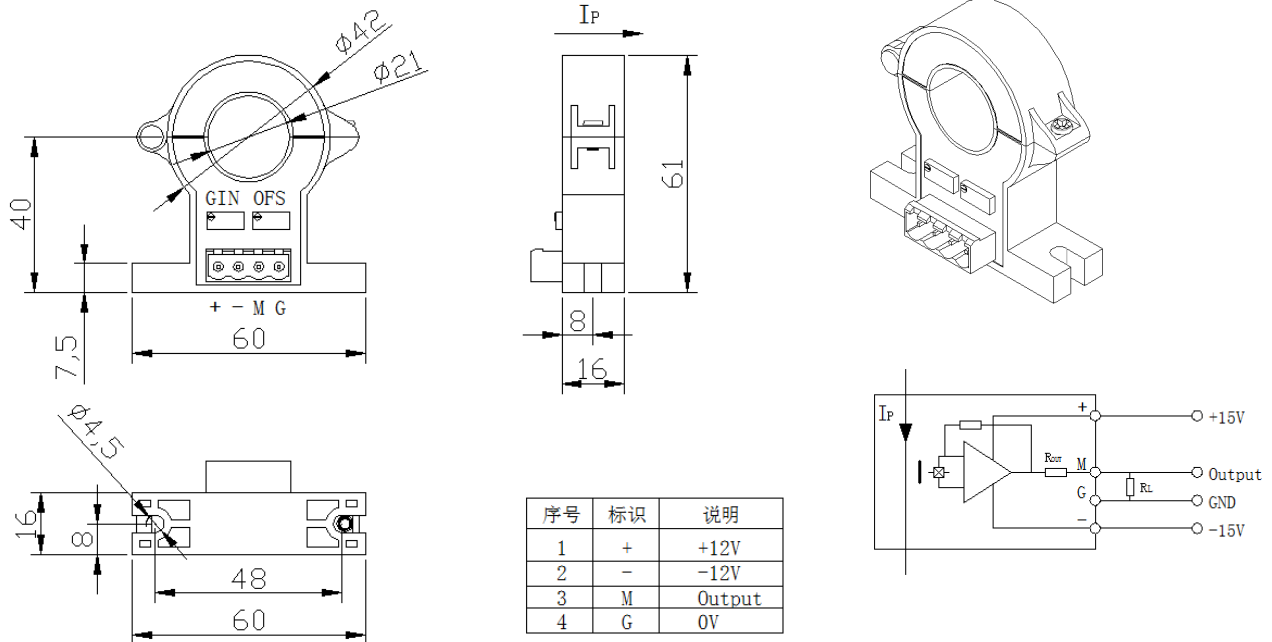

### SCY6R

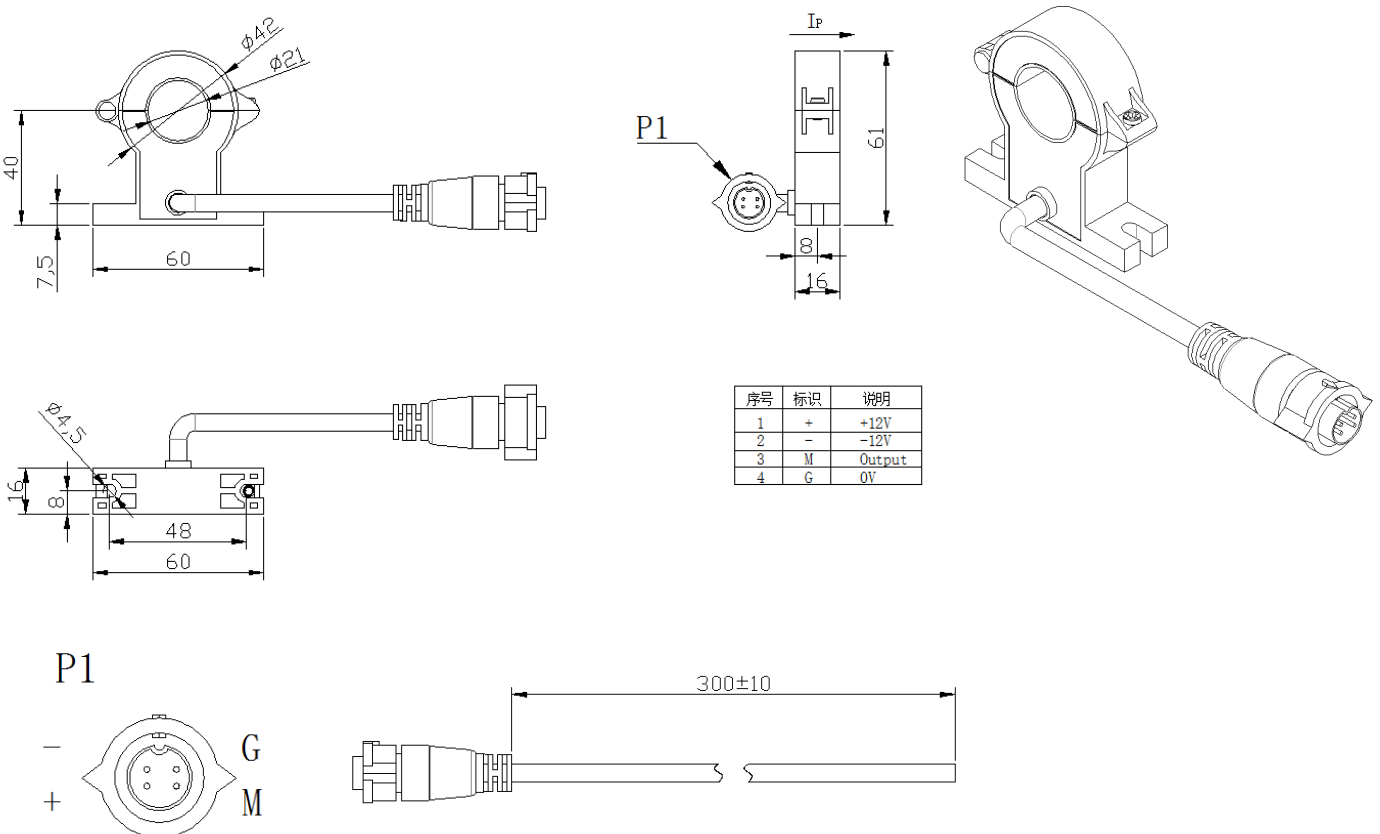

Shenzhen SoCan Technologies Co.,Ltd

SoCan is committed to continuously improving product quality, and the company reserves the right to update its products.

[www.szsocan.com](http://www.szsocan.com)

Notes:

1. Size error:  $\pm 1\text{mm}$ ;
2. Primary aperture:  $\varnothing 21\text{mm}$ ;
3. SCY6T output terminal: 2EDGVC-5.08-4P
4. SCY6R output interface: Amphenol BD-04AFMM-QL8XX
5. The IP indication direction is the positive direction of the current, OFS is the zero adjustment, and GIN is the output regulation;
6. Incorrect wiring may cause damage to the sensor.

Shenzhen SoCan Technologies Co.,Ltd

---

SoCan is committed to continuously improving product quality, and the company reserves the right to update its products.

[www.szsoacan.com](http://www.szsoacan.com)